

## EFFECT OF THE STRUCTURE FORMED AFTER BULK AND SURFACE HARDENING ON THE HARDNESS AND WEAR RESISTANCE OF 20Cr2Ni4A STEEL

Rakhadilov B.K.<sup>1</sup>, Satbaeva Z.A.<sup>1\*</sup>, Kozhanova R.S.<sup>1</sup>, Kowalewski P.<sup>2</sup>,  
Bayatanova L.B.<sup>1</sup>, Kalitova A.A.<sup>3</sup>

<sup>1</sup>"Plasma Science" LLP, Ust-Kamenogorsk, Kazakhstan, [satbaeva.z@mail.ru](mailto:satbaeva.z@mail.ru)

<sup>2</sup>Wroclaw University of Science and Technology, Wroclaw, Poland

<sup>3</sup>Institute of Composite Materials, Ust-Kamenogorsk, Kazakhstan

*The article presents the results of a comparative study of the effect of bulk and surface hardening on the structure and properties of 20Cr2Ni4A steel. Surface hardening was carried out by the electrolytic plasma method. Bulk quenching was carried out by heating to a temperature of 870 °C, followed by cooling in water and oil. The structural-phase states of 20Cr2Ni4A steel samples were studied by metallographic and X-ray structural analysis. Tribological tests of the samples were carried out according to the ball-disk scheme, and the microhardness of the samples was also determined. It has been determined that after volumetric and surface hardening, the hardness and wear resistance of 20Cr2Ni4A steel increase. In this case, the most significant change is observed in samples that have undergone electrolytic plasma hardening. It has been established that high values of hardness and wear resistance of 20Cr2Ni4A steel after electrolytic plasma hardening are associated with the formation of fine-needle martensite.*

**Keywords:** structure; phase composition; electrolytic plasma hardening; microhardness; wear resistance.

### Introduction

One of the most effective ways to improve the service characteristics of structural steels is the development of optimal heat treatment modes. This makes it possible to obtain products with certain specified characteristics that meet operational requirements, and on the other hand, to predict changes in the properties of parts and structures during manufacture and operation [1-3]. The martensitic structure, as a rule, provides structural steels with good physical and mechanical properties. To obtain a martensitic structure in steels, they are subjected to bulk or surface hardening. Case hardening is widely used to improve the durability of friction joint parts, which often experience high shock loads. Since, they must have high strength and hardness of the surface layer, combined with sufficient ductility of the core. The main difference between surface hardening and bulk thermal hardening is the short duration of the surface layer heating process and the high cooling rate due to heat dissipation into the inner layers of the metal. These factors influence greatly the structure of the hardened layer. The cooling rate manifests itself in the refinement of the structure of the surface layer. At present, high-frequency [4], gas-flame [5], plasma [6], electron-beam [7] and laser processing [8] are widely used for surface thermal hardening of steel parts in industry. Among them, plasma surface hardening has a number of advantages over the existing methods of thermal surface hardening in terms of its technical and economic indicators and the results of comparative analysis. The main advantage of plasma thermal hardening in comparison with laser hardening is the time spent on surface treatment, since the area of action of a plasma arc is larger than that of a plasma beam [6, 9].

One of the promising methods of plasma surface hardening is electrolytic plasma hardening [10-12]. During electrolytic plasma hardening, heating and cooling of the part is carried out in a water-based electrolyte. The plasma layer is formed in the gap between the liquid (electrolyte) electrode and the surface of the product when voltage is applied [12]. The result of a short stay of steel at hardening temperatures, as well as the occurrence of phase transformations in the temperature range above equilibrium, is an increase in the mechanical properties of the material in comparison with bulk hardening. In connection with the above, the goal of this research is to study the effect of bulk and surface hardening on the structure, hardness and wear resistance of 20Cr2Ni4A steel.

## Materials and methods

Structural alloyed 20Cr2Ni4A steel was used as the research object. Table 1 shows the chemical composition of the studied steel. Samples of 20Cr2Ni4A steel with dimensions of 10x10 mm were subjected to bulk and surface hardening. Bulk hardening of 20Cr2Ni4A steel samples was carried out in an evacuated quartz tube in a laboratory tubular furnace according to the following modes: quenching from a temperature of 870 °C, the holding time at a temperature of 870 °C was 0.5 h, and cooling was performed in water and oil. The first sample was cooled in water; the second sample was cooled in oil to room temperature.

**Table 1.** Chemical composition of 20Cr2Ni4A steel

Steel name	C	Si	Mn	Ni	S	P	Cr	Cu
20Cr2Ni4A	0.16-0.22	0.17-0.37	0.3-0.6	3.25-3.65	up to 0.025	up to 0.025	1.25-1.65	up to 0.3

Surface hardening of 20Cr2Ni4A steel samples was carried out by the electrolytic plasma method on an installation consisting of a 30-kW DC source, an electrolytic cell, a bath, a pump, a heat exchanger, and a stainless steel anode [12-14]. The EPH process was carried out in an electrolyte from an aqueous solution containing sodium carbonate (20%) and urea (10%) in the following mode: the applied voltage between the anode and the sample was 320 V, the current density was 25 A/cm<sup>2</sup>, and the plasma exposure time was 2 sec. In this mode, the samples were heated to ~ 850-900 °C. Cooling was carried out in a flowing electrolyte after turning the voltage off. Figure 1 shows a schematic view of the installation.

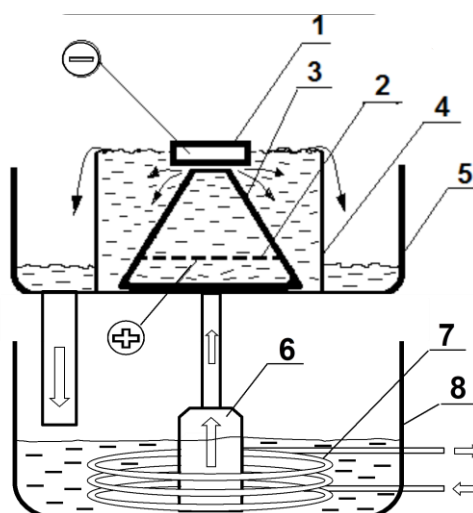

**Fig.1.** Scheme of the installation for electrolytic plasma treatment:

- 1 – processed sample (cathode), 2 – stainless steel anode, 3 – cone-shaped partition, 4 – electrolytic cell,  
5 – pallet, 6 – pump, 7 – heat exchanger, 8 – bath with electrolyte

The study of the phase composition of 20Cr2Ni4A steel samples before and after bulk and surface hardening was carried out on X'PertPRO X-ray diffractometer in Cu K $\alpha$  radiation in a continuous recording mode in the angle range from 20 to 85 °. Metallographic analysis was performed in a bright field on Altami MET 5C microscope at various magnifications. The microhardness of the samples was measured by the method of indentation of a diamond indenter on PMT-3M device in accordance with GOST 9450-76, at a load of 100 g and holding for 10 sec. Tribological tests were carried out on TRB3 tribometer under dry friction; a chromium-plated 100Cr6 ball with a diameter of 6 mm was used as a counter body; the friction path was 50 m at a speed of 3 cm/s and a load of 5 N.

## Results and discussion

Figure 2 shows the microstructure of 20Cr2Ni4A steel before and after bulk and surface hardening. Metallographic analysis showed that 20Cr2Ni4A steel in the initial state consists of a ferrite-pearlite structure. Pearlite makes up  $\sim 10\%$  of the total volume. The average grain size of ferrite is  $\sim 97 \mu\text{m}$ . After electrolytic plasma hardening and bulk hardening, a martensitic structure is formed. At the same time, after electrolytic plasma hardening, fine-acicular martensite with retained austenite is formed, and after bulk hardening in water and oil, coarse-acicular martensite with a small content of retained austenite is formed. After electrolytic plasma hardening and bulk hardening in water, undissolved cementite is observed in the steel structure. Electrolytic plasma hardening of the surface led to the formation of a highly inhomogeneous structure in the hardened zone. Due to the incompleteness of the austenitization processes in the hardened layer, fine-acicular martensite, undissolved cementite and retained austenite were formed (Fig. 2b).

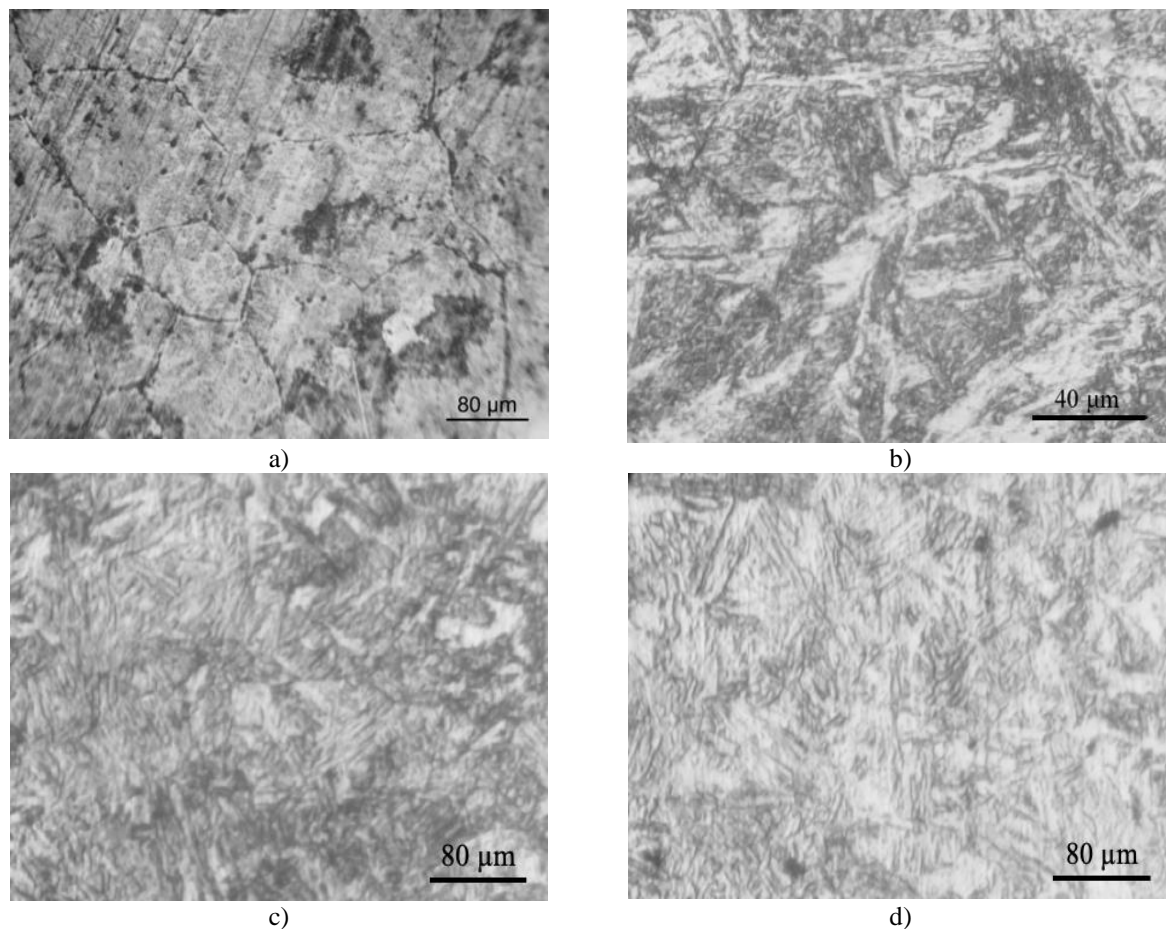

**Fig.2.** Microstructure of 20Cr2Ni4A steel before (a) and after surface (b) bulk hardening from  $T = 870 \text{ }^{\circ}\text{C}$  in water (c) and in oil (d)

The phase composition of the samples was studied before and after surface and bulk hardening. Figure 3 shows X-ray diffraction patterns of 20Cr2Ni4A steel samples. X-ray structural analysis showed that, in the initial states of 20Cr2Ni4A steel, diffractograms contain lines of the  $\alpha$ -phase and weak reflections of austenite. After electrolytic plasma hardening, lines of the  $\alpha$ -phase and weak reflections of austenite are also observed. Moreover, after bulk hardening in water and oil, only the lines of the  $\alpha$ -phase are present in the diffractogram. In this case, after surface and bulk hardening, broadening of the  $\alpha$ -phase line is observed, which indicates the formation of martensite. On the diffraction patterns of the samples after hardening, no cementite reflections were found, apparently, this is due to their low concentration, which does not allow detection by X-ray diffraction analysis.

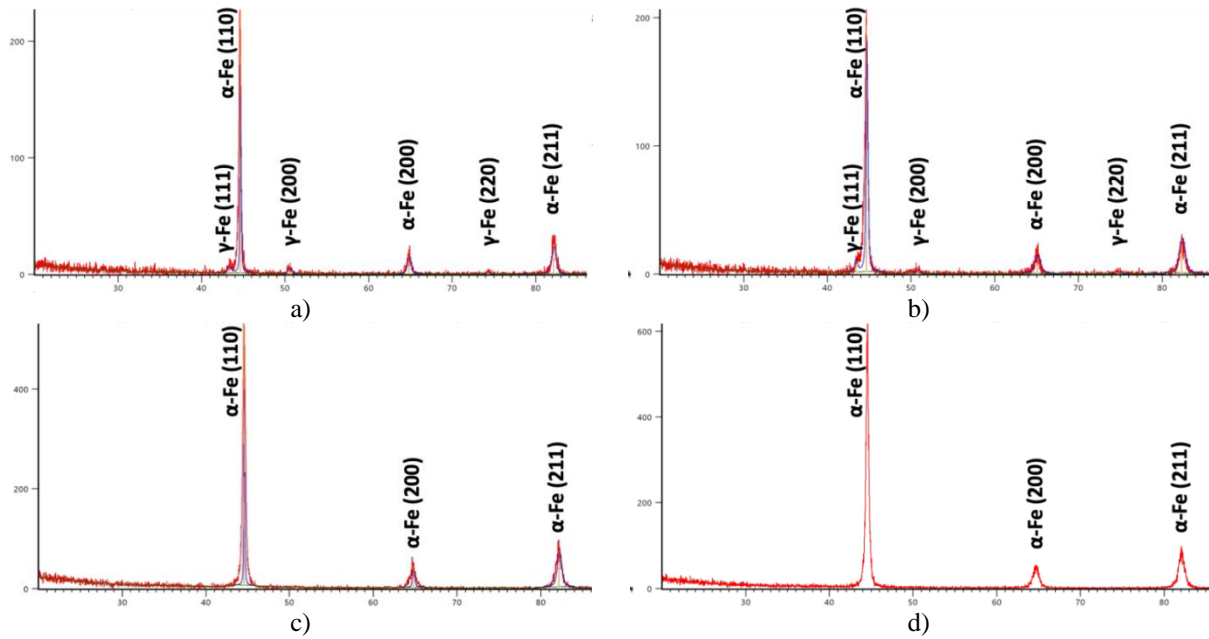

**Fig.3.** X-ray diffraction patterns of 20Cr2Ni4A steel before (a) and after surface (b) bulk hardening from  $T = 870\text{ }^{\circ}\text{C}$  in water (c) and in oil (d)

Hardness is one of the most important properties of the surface layer, which strongly depends on the rate of heating and cooling during hardening. Therefore, we studied the changes in the microhardness of 20Cr2Ni4A steel depending on the type and mode of hardening. Figure 4 shows the microhardness of 20Cr2Ni4A steel before and after surface and bulk hardening. After surface and bulk hardening, the microhardness of 20Cr2Ni4A steel increases. At the same time, the maximum increase in hardness is observed in samples treated by electrolytic plasma hardening. An increase in hardness up to 2 times during electrolytic plasma hardening is associated with the formation of fine-needle martensite. We found that after electrolytic plasma hardening a small amount of residual austenite is formed. But in spite of this the hardness is significantly higher than in traditional heat treatment. This is due to the formation of a highly dispersed metastable structure with a much higher density of dislocations in the surface layer [14, 15].

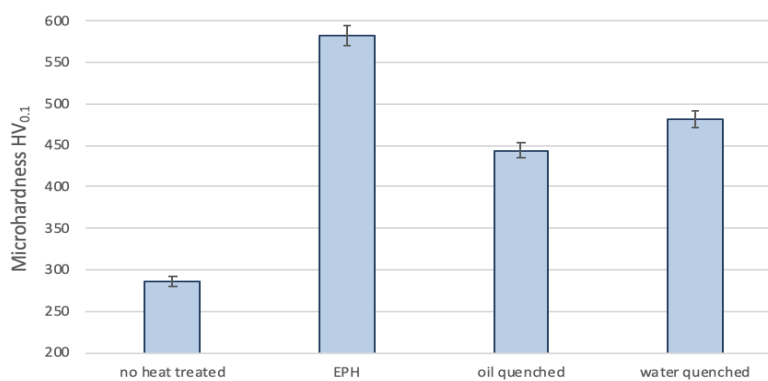

**Fig.4.** Microhardness of 20Cr2Ni4A steel before and after surface and bulk hardening

Figure 5 shows the results of tribological tests of 20Cr2Ni4A steel samples according to the ball-disk scheme. The wear resistance of the samples was characterized by the wear volume of the samples. The measurement results showed insignificant changes in the coefficient of friction (Figure 5a). Figure 5b shows that the hardened samples have a low wear rate compared to the original sample. At the same time, the highest wear resistance is shown by samples treated by electrolytic plasma hardening and bulk water hardening. The high wear resistance of these samples is due to the high hardness of the surface, as well as

high internal stresses that are formed during rapid cooling. Bulk hardening is accompanied by the formation of internal stress fields, the magnitude of which depends on the type of stress concentrator. Therefore, after bulk hardening, annealing is performed to relieve internal stress. In steels, stress concentrators are not microcracks, but the hard and brittle microstructures constituting them - carbides, or rather, local accumulations of carbides.

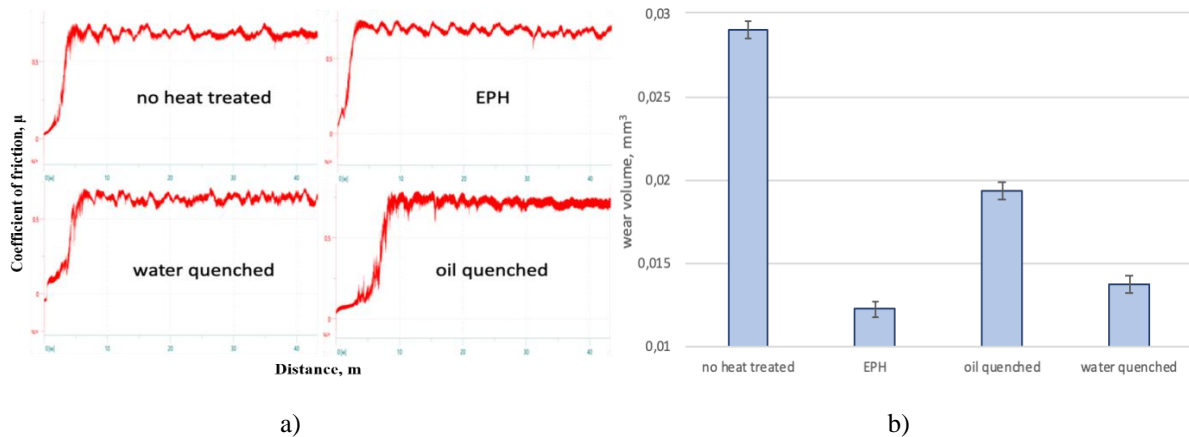

**Fig.5.** Graphs of the change in the coefficient of friction (a) and the wear volume (b) of 20Cr2Ni4A steel samples before and after surface and bulk hardening

For steels that have undergone electrolytic plasma hardening, there is no need for annealing due to the small thickness of the hardened layer. In this case, after electrolytic plasma hardening, the steel base remains viscous and the structure contains a significant amount of retained austenite, which acts as a damper during the propagation of microcracks and stresses.

Thus, plasma electrolytic hardening leads to an increase in the physical and mechanical properties of parts made of 20Cr2Ni4A steel. This is due to the fact that a structure with a high dislocation density is formed on the surface. A high degree of dissolution of the carbide phase, refinement of the grain structure, and an increase in the density of defects in the crystal structure after plasma electrolyte hardening leads to an increase in the operational properties of 20Cr2Ni4A chromium-nickel steel.

## Conclusion

1. Based on metallographic and X-ray structural analyzes, it was determined that after electrolytic plasma hardening, fine-acicular martensite with retained austenite is formed, and after bulk hardening in water and oil, coarse-acicular martensite is formed with a small content of retained austenite. At the same time, after electrolytic plasma hardening and bulk hardening in water, undissolved cementite is observed in the steel structure.

2. It was determined that after surface and bulk hardening the microhardness of 20Cr2Ni4A steel increases. At the same time, the maximum increase in hardness is observed in samples treated with electrolytic plasma hardening. It was found that an increase in hardness up to 2 times during electrolytic plasma hardening is associated with the formation of fine-acicular martensite and the formation of a highly dispersed metastable structure with a high density of dislocations in the surface layer.

3. Tribological tests have shown that the hardened samples have high wear resistance compared to the initial samples. At the same time, the highest wear resistance was shown by samples treated with electrolytic plasma hardening and bulk water hardening. The high wear resistance of these samples is due to the high hardness of the surface, as well as high internal stresses that form during rapid cooling. At the same time, after EPH, the steel base remains viscous and a significant amount of retained austenite is present in the structure, which acts as a damper during the propagation of microcracks and stresses.

## Acknowledgments

This paper was performed within the grant financing of scientific research for 2021-2023 of Committee of the Science of the Ministry of Education and Science of the Republic of Kazakhstan. Grant (AP09058547).

## REFERENCES

- 1 Kurdyumov V.G., Utevsky L.M., Entin R.I. *Transformations in iron and steel*. Moscow, 1977, 236p. [in Russian]
- 2 Schastlivtsev V.M., Mirzaev D.A., Yakovleva I.L. *The structure of thermally processed steel*. Moscow, Metallurgiya, 1994, 288 p. [in Russian]
- 3 Vassilyeva A.G. *Deformation hardening of hardened structural steels*. Moscow, Mashinostroenie, 1981, 231p. [in Russian]
- 4 Ivancivsky V., Parts K., Popov V. Depth Distribution of Temperature in Steel Parts during Surface Hardening by High Frequency Currents. *Applied Mechanics and Materials*. 2015, 788, pp. 129 – 135. <https://doi.org/10.4028/www.scientific.net/amm.788.129>
- 5 Petrov G.L., Burov N.G., Abramovich V.R. *Technology and equipment for gas-flame processing of metals*. Leningrad, Mashinostroenie, 1978, 277 p. [in Russian]
- 6 Leshchinsky L.K., Samotugin S.S., Pirch I.I., Komar V.I. *Plasma surface hardening: monograph*. Kiev, 1990, 109p. [in Russian]
- 7 Poletika I.M., Golkovsky M.G., Perovskaya M.V. Electron beam hardening of the surface layer of steel outside vacuum. *Physical Mesomechanics*. 2006, No. 9, pp. 181-184.
- 8 Smirnova N.A., Misyurov A.I. Features of structure formation during laser processing. *Engineering journal: science and innovations*, 2012, No. 6 (6), pp. 115-129. [in Russian]
- 9 Safonov E.N. *Plasma hardening of machine parts. Monograph*. Berlin, Direkt-Media, 2014, 165 p.
- 10 Belkin P.N., Kusmanov S.A. Plasma Electrolytic Hardening of Steels: Review. *Surface Engineering and Applied Electrochemistry*. 2016, Vol.52, No.6, pp. 531-546. doi:10.3103/S106837551606003X.
- 11 Rakhadilov B., Zhurerova L., Pavlov A. Method of Electrolyte-Plasma Surface Hardening of 65G and 20GL Low-Alloy Steels Samples. *IOP Conf. Series: Materials Science and Engineering*, 2016, Vol.142, pp. 1-7.
- 12 Rakhadilov B.K., Buranich V.V., Satbayeva Z.A., et al. The cathodic electrolytic plasma hardening of the 20Cr2Ni4A chromium-nickel steel. *Journal of Materials Research and Technology*, 2020, Vol.9, No. 4, pp. 6969-6976.
- 13 Zhurerova L.G., Rakhadilov B.K., Popova N.A., et al. Effect of the PEN/C surface layer modification on the microstructure, mechanical and tribological properties of the 30CrMnSiA mild-carbon steel. *Journal of Materials Research and Technology*. 2019, Vol.9, No. 1, pp.78-85.
- 14 Rakhadilov B., Kengesbekov A., Zhurerova L., et al. Impact of electronic radiation on the morphology of the fine structure of the surface layer of R6M5 steel. *Machines*. 2021, Vol. 9(2), No. 24, pp.1-9.
- 15 Rakhadilov B., Satbayeva Z., Baizhan D. Effect of electrolytic-plasma surface strengthening on the structure and properties of steel 40kHN. *METAL 2019 - 28th International Conference on Metallurgy and Materials, Conference Proceedings*, 2019, pp. 950-955.