

UDC: 621.311.24

ABOUT HIGH EFFICIENCY OF TWO-ROTOR WIND POWER UNIT BIDARRIEUS-2

Yershina A.K.¹, Yershin Sh.A.²

¹Kazakh National Women's Teacher Training University, Almaty, Kazakhstan, ainakul82@mail.ru

²al Farabi Kazakh National University, Almaty, Kazakhstan

The article discusses the design features of the wind turbine Bidarrieus-2 with an abnormally high wind power coefficient. The basic design of HBI-rotor of the turbine Bidarrieus-2 is shown. Due to the twin-rotor construction the wind turbine Bidarrieus-2 has much more efficient than all modern wind power devices. In calculating of the power the wind turbine rotational moment has been taken into account. The study results of wind energy that can be converted by the Bidarrieus-2 wind turbine are confirmed it's uniqueness.

Keywords: wind turbine, Darrieus, Bidarrieus-2, HBI-rotor, wind power coefficient

Introduction

Now the propeller-type wind turbines with installed capacity up to several megawatts are widely used. On the basis of many years of experience, the technology of creating a high-power WPU of a propeller-type wind turbine has been mastered [3-8]. But practice shows that the higher the capacity of wind farms, the wider the lifeless territory in these regions (birds, fauna, including the population, leave these places). Also, the gyroscopic effect of a propeller wind turbine can lead to emergency situations [9].

More preferable are the carousel type Darrieus wind turbines, which have the symmetrical wing form NASA and operate on the lifting power of the blades. The overall dimensions of such devices are much less at the same values of the installed power. The material consumption and space occupied by these devices is much less than the propeller ones. At the wind turbine Darrieus the flow is uninterrupted, and as a result, its work is almost noiseless.

It is well known that in the development and creation of any machine an important characteristic of utility (if not the main) is the value of the efficiency factor. In its work, the ratio of the benefits of using this machine to the required costs, such as cost, operating costs, service life, payback, etc., is indicative [1-2]. This also applies to the operation of wind power unit (WPU), for which the efficiency of the unit is determined by the efficiency of wind energy that is named as a power coefficient. The higher the value of this coefficient, the more effective is the economic and commercial value of the WPU [3-11].

At present, there are no serially produced vertically-axial Darrieus, wind turbines of the megawatt capacities on the Kazakhstan, Russian and international markets. Among foreign manufacturers, the low-power production of low-power VA wind turbine can be specified in Finnish company Ropatec, German firms Aseptor, Bekar, Chinese firm Alibaba, etc. Ukrainian, Russian and foreign scientists are interested in vertical axis machines [2, 3, 8]. All these works deal with the study of vertical-axial wind turbines Darrieus, with a single rotation shaft.

For more than 20 years paper authors are conducting research on the development of vertical-axial wind turbine Darrieus type with two coaxially located rotation shafts. Three versions of two-rotor carousel type wind turbines with a high coefficient of wind energy use (CWEU) are proposed [10-11]. All inventions are protected by patents of the Republic of Kazakhstan and the Russian Federation. Let us consider the structural features of the latter construction.

1. Bidarrieus-2 construction

Development and creation of the two first versions of two-rotor wind power units (Bidarrieus-1, HBI-rotor) lead to the possibility of creating the most unique machine that surpasses any modern wind power units by all parameters (from high efficiency to the simplicity of maintenance). It is called a WPU Bidarrieus-2 with HBI-rotor, and in Fig.1 the basic design of HBI-rotor is shown.

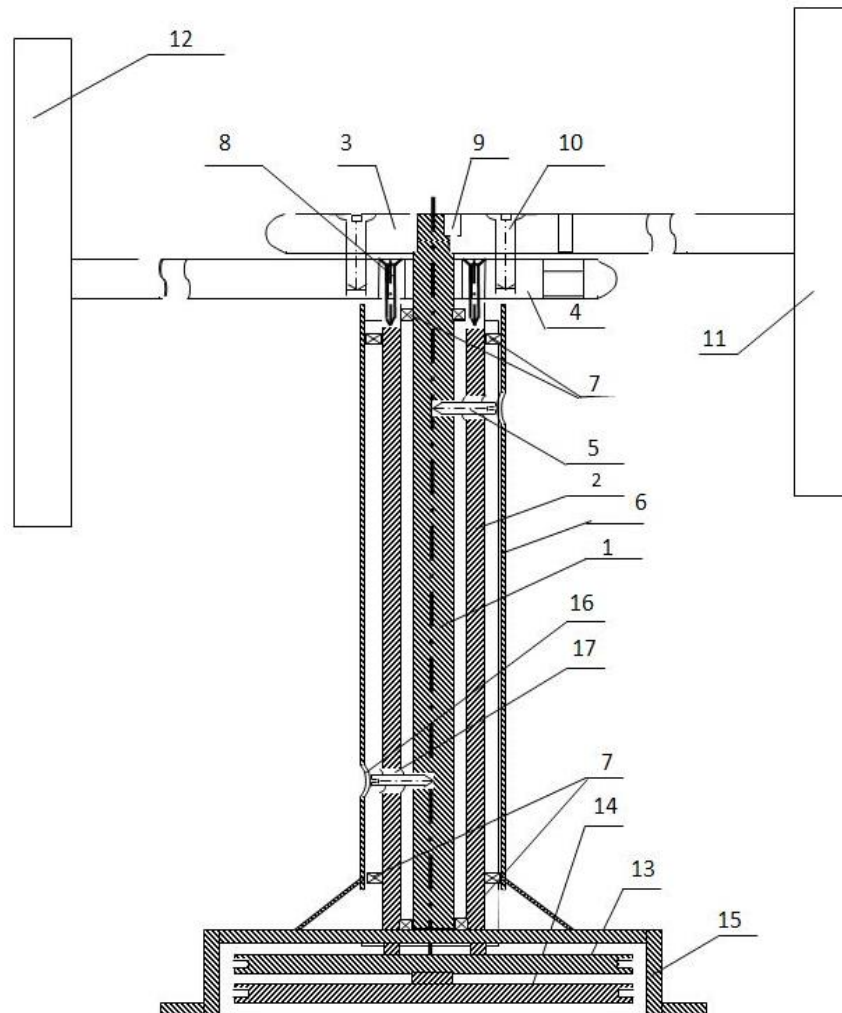

Fig. 1. Basic design of HBI-rotor of the turbine Bidarrieus-2:

1 - central shaft, 2 - external shaft, 3 - top span with cover blade connected with central shaft, 4 - lower span connected with external shaft, 5 - fingers for fixation of an angle between spans, 6 - external stationary case, 7 - bearings, 8 - bolts connecting span 4 with external shaft, 9 - spline, 10 - bolts connecting spans 3 and 4, 11 - blade connected with the top span, 12 - blade connected with the lower span, 13 – pulley connected with external shaft 2, 14 - pulley connected with central shaft 1, a 15 - figured frame for fastening, 16 and 17 - opening for fingers of fixation of an angle between spans 3 and 4.

Unlike the Darrieus design with a single rotation shaft, where a straight run is connected to two working blades, a wind power plant with two coaxially located rotation shafts is proposed. Coaxially installed shafts of rotation are separated from one another by bearing bearings, which makes it possible for them to rotate autonomously: as coordinated in the same direction and in opposite directions. This unit is a two-blade system. The system consists of two semi-spans with one working each blade, one of the semi-spans is jointed with the central rotary shift and the other –

with the external one. As a result, each working blade jointed with this or other semi-spans work independently. Encumbrance on the way of the wind reduces. This principle has been put in a basis of creation of WPP with HBI- rotor and this represents originality and novelty of the offered WPU. The both spans must rotate in one and the same direction with the same angular velocity $\bar{\omega}$. This results in the increase of the area being swept.

Thus, each of the two working blades rotates independently on the area being swept in the form of ring surfaces equal to the diameter of the wind turbine and the width equal to the length of the working blades. The both oppositely arranged blades balance each other and are independent. Correspondingly, the second blade with a semi-span rotates the external shaft and has the area being swept of practically the same kinds as the blade jointed with the central shaft.

Because two-rotor carousel type wind turbine Bidarrieus-2 consists from two autonomous systems or two aerodynamically equidistant nodes that balance each other as a result of a rigid connection through metal bearings. Therefore, it is sufficient to consider one of these units, for example, the work of the central shaft due to the influence of the wind flow on blades 1 and 4 (Fig. 2). This allows determining the technical-economical characteristics of each assembly independently on one another. The results obtained on the first assembly can be adequately transferred to the second wind power assembly. Wind turbine Bidarrieus-2 has 2 coaxial rotational shafts separated from each other by bearings 9, which allows them to rotate autonomously.

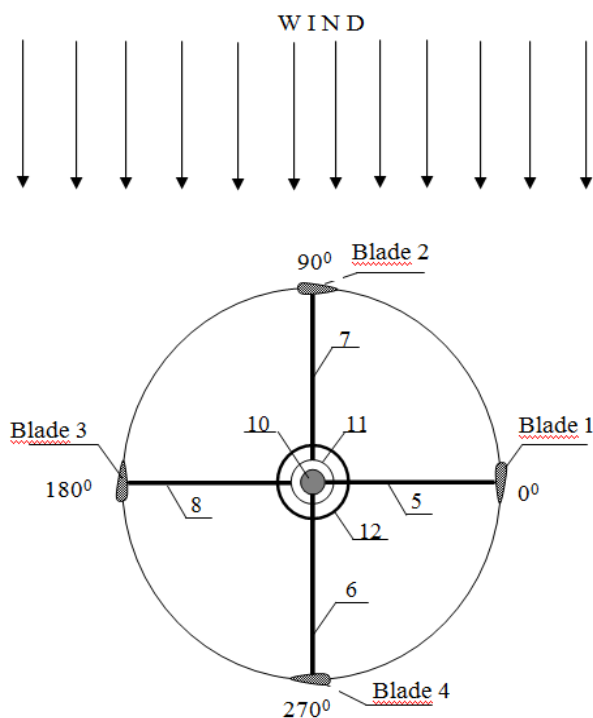

Fig.2. The scheme of positions of both assemblies during rotation of wind turbine Bidarrieus-2 (designations are the same as in Fig. 1)

Fig. 2 schematically shows the joint of semi-spans 5 and 6 and blades 1 and 4 with the central shaft of rotation 10 and joint of semi-spans 7 and 8 and blades 2 and 3 with external shaft 11. The external large circle is a fixed casing 12. Between this casing 12 and external shaft 11 there are bearings, like in our other two-rotor machines. And the second row of bearings is between the central shaft 10 and external shaft 11. The increase in ξ is due to the work of both assemblies. The system with the central shaft of rotation is the first assembly of Bidarrieus-2. A similar assembly consists of semi-spans 7 and 8 with blades 2 and 3 jointed with the external shaft of rotation 11.

Thus, WPU Bidarrieus-2 consists of two assemblies working independently of each other. The assembly has a special constructive form being know-how.

2. Calculation of the Bidarrieus-2 wind turbine power

The power N_t , which is developed by the Darrieus WPU with one rotation shaft, can be determined according to the well-known formula

$$N_t = \xi S \rho \frac{U^3}{2}, \quad (1)$$

where, $S = 2\pi r_0 \ell$ – flowed around area, ρ – air density, U – wind speed, ξ – efficiency of wind power.

The wind turbine capacity can also be determined if the rotary moment of the wind turbine M_{turb} is known

$$N_{turb} = \omega \cdot M_{turb}, \quad (2)$$

where $\vec{\omega}$ – the angular speed of rotation of the turbine shafts.

Rotary moment of the turbine:

$$M_{turb} = r_0 (|\vec{R}_\tau| - |\vec{R}_D|), \quad (3)$$

where \vec{R}_τ – tangential component of the lifting power

$$\vec{R}_\tau = \vec{R}_l \sin \alpha. \quad (4)$$

The lifting power of the blade profile \vec{R}_l is directed perpendicular to the wind attack speed \vec{V} and its volume is determined by [1, 2] formula

$$|\vec{R}_l| = C_y(\alpha) L \rho \frac{V^2}{2}, \quad (5)$$

where $C_y(\alpha) = \sqrt{2\pi} \sin \alpha$ – coefficient of the lifting power, L – length of the blade of symmetric profile with the chord equal to ρ and V – attack speed.

The force of air resistance to the movement of the blade is registered [12] in the form of the following dependence

$$|\vec{R}_D| = C_x(\alpha) L \rho \frac{V^2}{2} \cos \alpha, \quad (6)$$

where $C_x(\alpha) = 0.014 + \sin^2 \alpha$ – coefficient of resistance of wing profile.

The value of the blade chord which represents wing NASA profile 0021 is determined by the following dependence:

$$b = 1 / r_0$$

r_0 – length of semi-spans of the wind turbine.

Attack speed V is determined [1] by the formula:

$$|\vec{V}| = |\vec{U}| \cdot \sqrt{1 + \chi^2 + 2\chi \cos \theta} = |\vec{U}| \cdot \sqrt{\sin^2 \theta + (\chi + \cos \theta)^2} \quad (7)$$

Equating two ratios (1) and (2) to each other we will write down:

$$\xi \cdot S \cdot \frac{\rho \cdot U^3}{2} = \omega M_t, \quad (8)$$

Substituting values of the wind turbine parameters we will eventually have the following dependence the solution of which allows determining the value χ for Bidarrieus-2.

$$\chi^2 + 2\chi \cos \theta + 1 = \frac{\xi \cdot S \cdot U}{\omega \cdot L \cdot b \cdot r_0 \cdot [C_y(\alpha) \cdot \sin \alpha - C_x(\alpha)]} \quad (9)$$

As the formula turns out bulky, we will enter designation of A

$$A = \frac{\xi \cdot S \cdot U}{\omega \cdot L \cdot b \cdot r_0 \cdot [C_y(\alpha) \cdot \sin \alpha - C_x(\alpha)]} \quad (10)$$

For the purpose of simplification of calculations we will use the value equal to the difference between the dimensionless value A and a unit, denoted B

$$B = 1 - A$$

Then expression (9) is transformed into a simpler form

$$\chi^2 + 2\chi \cos \theta + B = 0 \quad (11)$$

From here tip speed ratio χ for Bidarrieus-2, in $\cos 90^\circ=0$, will be equal to $\chi=15.33$. On the basis of this value the Bidarrieus-2 unit makes 24.41 revolutions per second. Taking into account the volume of removed power (39.4 kW) at one revolution of a regular wind turbine Darrieus it is possible to determine the power removed from a wind flow by Bidarrieus-2 wind turbine, with two shafts of rotation taking into account the number of its rotations (24.41 rps). Taking into account the twice increase in the power removed from a wind flow when using two semi-spans, we have the dependence:

$$39.4 \text{ kW} \times 2 \times 24.41 \text{ rps} = 1924 \text{ kW}.$$

From this, it is concluded that the wind turbine Bidarrieus-2 with the wind wheel diameter of 6 m removes from a wind flow by each unit the power of 1924 kW, and by both units – 3848 kW (see Fig. 2) at the parameters mentioned above. Wind turbine Darrieus removes 394 kW of power from a wind flow.

Thus, it follows that Bidarrieus-2 with both units removes power from the wind flow 10 times more than regular Darrieus unit. Firstly, such high power is related to the use of peculiar construction of semi-spans which double the power removed from a wind flow. Secondly, it is related to the presence of two independently working units of the device which once again doubles the power of Bidarrieus-2.

Not the last role is played by the high wind speed (30 m/s) which is also taken into account in calculation. The calculation of the power for a simple Darrieus wind turbine with one rotation shaft was carried out at following main parameters: wind power efficiency of $\xi=0.30$, degree of tip speed ratio $\chi=6.2$ [13]. Dimensions of the Darrieus aggregate: the diameter of the wind wheel (the wind turbine span) is 6 m, the length of the working blades is 4 m. The wind speed is 30 m/s. At a given rate of speed χ , a simple Darrieus wind generator, makes 10 rps, this allowing it to operate at high wind speeds, i.e. its service life will be practically unlimited. For the twin-screw Bidarrieus-2 wind turbine, the power consumed by the two DC generators is added together.

Conclusion

The presented two-rotor units are unique, both in terms of design and technical and economical indicators, and have no analogues in the world. Bidarrieus-2 wind turbine is able to occupy a dominant position in wind power, due to the high efficiency of wind energy. The results of the calculations show that for a small installation size (span diameter of about 6-7 meters) Bidarrieus-2 can generate megawatt power from the wind current. According calculations the wind energy utilization factor for the Bidarrieus-2 turbine can reach 0.7. It has been established that high

efficiency of twin-rotor wind turbines is achieved with a wind speed of at least 20 m / s. These findings determine the importance for investment in order to perform full-scale tests of the Bidarrius-2 wind turbine and industrial production in the future not only in Kazakhstan.

REFERENCES

- 1 Bezrukikh P.P. [Ispol'zovanie energii vetra] *Wind power use*. Moscow, 2008, 196 p.[in Russian]
- 2 Yershina A.K., Yershin Sh.A., Zhapbasbayev U.K. *Fundamentals of the theory of the wind turbine Darrieus*. Almaty, Kazakh state ISTI, 2001, 104 p. [in Russian]
- 3 Renewables 2018 Global Status Report (GSR). World Wind Energy Association, June 4, 2018. Available at: <http://wwindea.org/11961-2/>
- 4 Timothy J. McCoy, Dayton A. Griffin. Control of Rotor Geometry and Aerodynamics: Retractable Blades and Advanced Concepts. *Wind Engineering*. 2008, Vol. 32, Issue 1, pp. 13–26.
- 5 Kayan V.P., Kochin V.A., Lebid O.G. Studying the Performance of Vertical Axis Wind Turbine (VAWT) Models with Blade Control Mechanism. *Intern. Journal of Fluid Mechanics Research*, 2009, Vol.36, Issue 2, pp. 154 – 165.
- 6 Horiuchi K., Ushiyama I., Seki K. Straight Wing Vertical Axis Wind Turbines: A Flow Analysis. *Wind Engineering*. 2005, Vol. 29, Issue 3, pp. 243 – 252.
- 7 Yershina A.K., Yershin Sh.A. Vertical-axial compound wind turbine of rotor type. *Proceedings of the ASME-ATI-UIT-2010. Thermal and Environmental in Energy Systems Conference*. Sorrento, Italy, 2010, pp. 621 – 625.
- 8 Yershina A.K., Nursadykova Zh.K., Borybaeva M.A. Analysis of developing wind power apparatus in Kazakhstan. *Eurasian Physical Technical Journal*, 2016, Vol.13, No. 2(26), 99–106.
- 9 Yershina A.K., Yershin Sh.A., Yershin Ch.S., Manatbayev R.K. RK Patent No. 31662 F03D 3/06. Published Nov. 15, 2016.
- 10 Yershina A.K. New perspective version of Bi-Darrieus windturbine. *Journal of International Scientific Publications: Materials, Methods and Technologies*. 2014, Vol.8, pp. 465 - 472.
- 11 Yershina A.K., Yershin Sh.A., Manatbayev R.K., et al. AP Bi-Darrieus wind turbine. *Proceedings of the 15th Intern. Scient. Conference on Renewable energy & innovative technologies* (Bulgaria, 2016), Vol.1, pp. 1 – 8.